

Technical Specification - CTH/8 Chair Trolley

The CTH/8 is a 2-wheeled chair trolley with padded panel for transporting stacks of Evosa chairs. The additional front loop slides under the seat frame to ensure the stack is supported during use. The trolley enables the chairs to be moved with maximum ease and minimum effort.

Please note: this trolley is only suitable for the Evosa range, alternative trolleys are available for other ranges.

Features include:

- Tubular mild steel construction throughout
- Padded panel for protection of mesh upholstery
- Front loop seat support
- Pewter hammer finish powder coated frame
- Rubber wheels

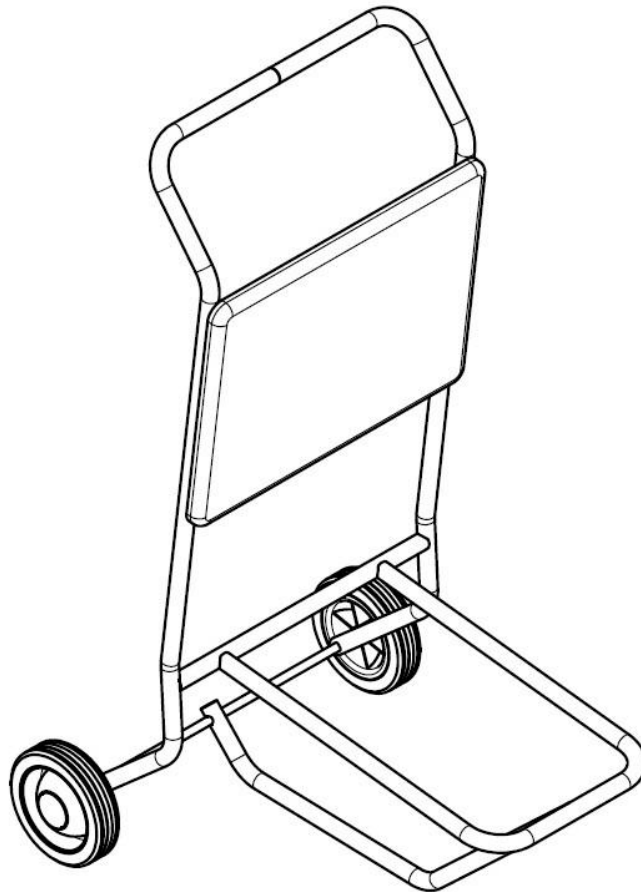

Specifications (cm)				
Description	Width	Length	Height	Weight
CTH/8	65.5	80	125	10.3kg approx.

Burgess Furniture Ltd

Hanworth Trading Estate, Feltham, Middlesex, TW13 6EH, UK
 Telephone: +44 (020) 8894 9231 / Fax: +44 (020) 8894 2943
 Email: sales@burgessfurniture.com / Web: www.burgessfurniture.com

