



Burgess Furniture Ltd  
Hanworth Trading Estate  
Feltham  
Middlesex  
TW13 6EH  
United Kingdom

Tel: +44 (0)20 8894 9231  
Fax: +44 (0)20 8894 2943  
Email: [sales@burgessfurniture.com](mailto:sales@burgessfurniture.com)  
Web: [www.burgessfurniture.com](http://www.burgessfurniture.com)

# **A-Fold Tables**

## **Handling, Operation & Maintenance** **Manual**

# CONTENTS

---

<u>SECTION</u>	<u>PAGE</u>
<b>Section 1- Introduction</b>	<b>3</b>
1.1 About This Manual	3
1.2 Health & Safety (UK)	3
<b>Section 2 – Handling, Storage &amp; Operation</b>	<b>4</b>
2.1 Handling	4
2.2 Storage	4
2.3 Operation	5
<b>Section 3 – Maintenance &amp; Repair</b>	<b>6</b>
3.1 General	6
3.2 Maintenance Schedule	6
3.3 Cleaning	6
3.4 Inspection & Repair	6
3.5 Lubrication	7

# SECTION 1 - INTRODUCTION

---

## 1.1 About This Manual

- 1.1.1 This manual is intended for the instruction and guidance of personnel charged with the handling, operation and maintenance of Burgess System-C tables.
- 1.1.2 The procedures given in this must be read and understood by all relevant personnel.
- 1.1.3 Some procedures given should only be carried out by relevant specialists. This will be flagged where appropriate.
- 1.1.4 All relevant diagrams are to be found within this manual.
- 1.1.5 Burgess Furniture cannot be held liable for any loss, damage or injury resulting from failure to follow the procedures given.

## 1.2 Health & Safety (UK)

- 1.2.1 It is the Employers duty under the Health & Safety at Work Act 1974 to ensure all operational staff are aware of manual handling recommendations under the Manual Handling Operations Regulations 1992 (SI 1992 No. 2793).
- 1.2.2 Assessment should address itself to (a) task, (b) load, (c) working environment, and (d) individual capability.
- 1.2.3 Please refer to relevant brochure for individual weights or contact Burgess Furniture Ltd.

## SECTION 2 – HANDLING, STORAGE & OPERATION

---

### 2.1 Handling

- 2.1.1 To minimise the risk of personal injury and / or damage to tables, it is recommended that tables are transported using our purpose-built Burgess table trolleys.
- 2.1.2 Generally, tables weighing less than 25kg may be handled by one person of average strength and stature. Tables weighing more than 25kg should only be handled by two (or more) personnel as required.
- 2.1.3 Always use the correct Manual Handling lifting technique – legs bent, back straight, head up.
- **If the individual feels the task is too much for them alone they should seek assistance rather than risk injury and / or damaging the table.**

### 2.2 Storage

- **Unless specified, Burgess products are not intended for outside use and must not be stored in sunlight, rain, dew, or salt air.**
- 2.2.1 It is recommend that A-Fold tables are stored on purpose-built Burgess table trolleys. These provide the safest, most convenient form of storage and transportation.
- 2.2.2 Tables should be stored flat, stacked one on top of the other. The plastic corner mouldings on the underside incorporate protective feet for this purpose.

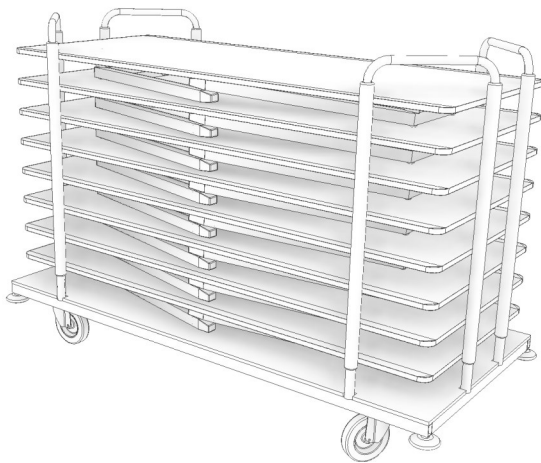

TTF/C Table Truck

- **It is not recommended that A-Fold tables are stored upright as this could cause damage to the edges, and the tables to permanently bow.**

## 2.3 Operation

2.3.1 Observing the handling instructions (see 2.1 Handling) remove the table from the trolley and carefully stand the table upright on-edge against a wall or have an assistant hold the table in this position.

- **If the floor is not carpeted, it is strongly recommended that a sheet of cardboard or similar is laid down first to protect the edges of the table top.**

2.3.2 Grasp the leg frame and pull to swing the leg out.

2.3.3 Push firmly on the locking mechanism to secure the leg in this position.

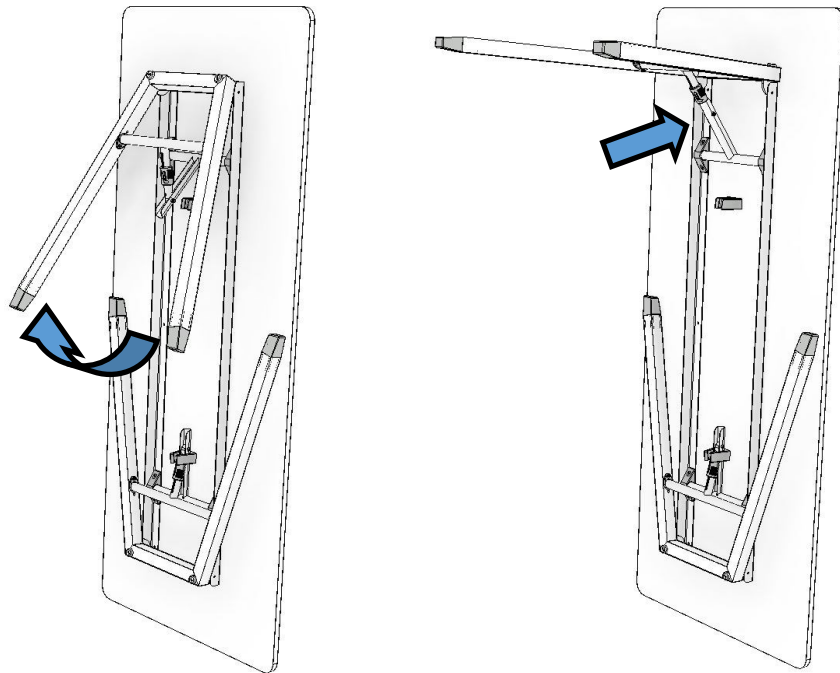

2.3.4 Slide the locking slide along the tube toward the centre of the table until you feel it has reached the end of the slot, then twist in the direction of the arrow

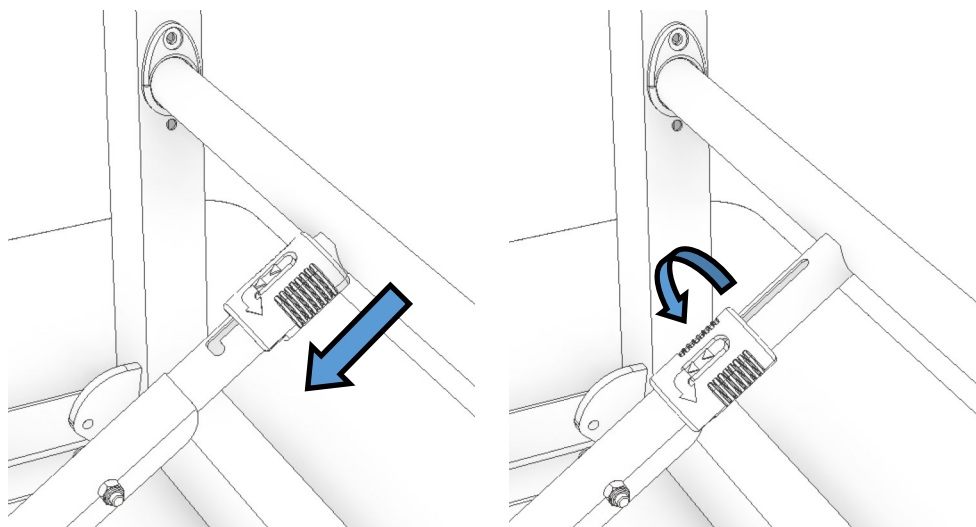

2.3.5 Repeat 2.3.2 - 2.3.4 for the opposite leg frame.

2.3.6 Carefully set the table down, ensuring that all four feet are stable on the ground.

---

## SECTION 3 – MAINTENANCE & REPAIR

---

### 3.1 General

- 3.1.1 All Burgess products are designed to give a long, trouble free working life with the minimum of maintenance and as such there are no user- serviceable parts. However, there is still a requirement for the operator to carrying out simple periodic inspection and maintenance as detailed below.
- 3.1.2 The maintenance procedures given should be carried out with the table unfolded and ready for use. (See Section 2 – Handling, Storage & Operation.)
- 3.1.3 Light damage as outlined below may be repaired by (or by agents of) the operator. More severe damage should be referred to Burgess Furniture Ltd.

### 3.2 Maintenance Schedule

- 3.2.1 The following maintenance procedures should be carried out at least every 3 months under normal operating conditions, or every 1 month under severe contract conditions.

### 3.3 Cleaning

- 3.3.1 Table underframes should be cleaned using a damp cloth and, where necessary, a mild soap cleaning agent.
- **Abrasive scourers should not be used.**
- 3.3.2 High Pressure Laminate & Real Wood Laminate tops should be cleaned using a damp cloth and a mild detergent, then dried with a soft lint-free cloth. Do not use any form of furniture polish on laminate table tops as this will result in smearing.
- **DO NOT use bleach or any other caustic / solvent based cleaner as permanent damage to the top will result.**

### 3.4 Inspection & Repair

- **Inspections must be carried out by a competent person. All defective tables must be immediately removed from service. Repairs must only be carried out by competent personnel.**
  - **Referring to Section 2 – Handling, Storage & Operation:**
- 3.4.1 Operate the leg folding mechanisms and check that all moving parts are free from damage and function smoothly.
- 3.4.2 Inspect the locking mechanism on the underside of the top, ensuring that all screws are secure.
- 3.4.3 Inspect the underframe on the underside, ensuring that it is secure and all screws fitting it to the table top are in place.
- 3.4.4 Inspect the plastic feet fitted to the underside of the leg frame foot rail. There should be one foot at each end, totalling 4 feet. Any missing or damaged feet should be replaced.

**3.4.5 High Pressure Laminate tops with hardwood lipping:** Light scratches and / or dents to the lipping may be repaired by rubbing down and re-staining. Scratches to the laminate itself can be improved using a colour matched filler, but it will be impossible to match the grain pattern.

**3.4.6 Formica tops:** Scratches to the Formica surface can be improved using a colour matched filler, but it will be impossible to match the grain pattern. Formica tops are edged with a high impact plastic which is very resistant to damage. Any damage that does occur will require the edging to be replaced.

- **Laminate & Formica repairs: These are specialist tasks and should only be performed by an experienced carpenter or woodworker. If the top is more severely damaged it will be unlikely that a satisfactory repair can be effected and the top should be replaced.**

3.4.7 More severe damage should be referred to Burgess Furniture Ltd.

- **ANY DEFECTIVE TABLES MUST BE REMOVED FROM SERVICE IMMEDIATELY.**

### **3.5 Lubrication**

The folding action of the leg frames can be kept in top condition by the application of a single drop of light oil to all pivot points once every 6 months under normal operating conditions, or every 2 months under severe contract conditions.